

PARKING-E

Front Parking Sensor Smart Switch

The Front Sensor Smart Switch is designed to automatically power a front parking sensor kit when reverse gear is engaged and maintain power for approximately 30 seconds following the disengagement of reverse gear. This Smart Switch is compatible with all PARKING-E parking sensor kits designed for fitting to the front of vehicles. This Smart Switch is only compatible with vehicles with 12 Volt electrics.

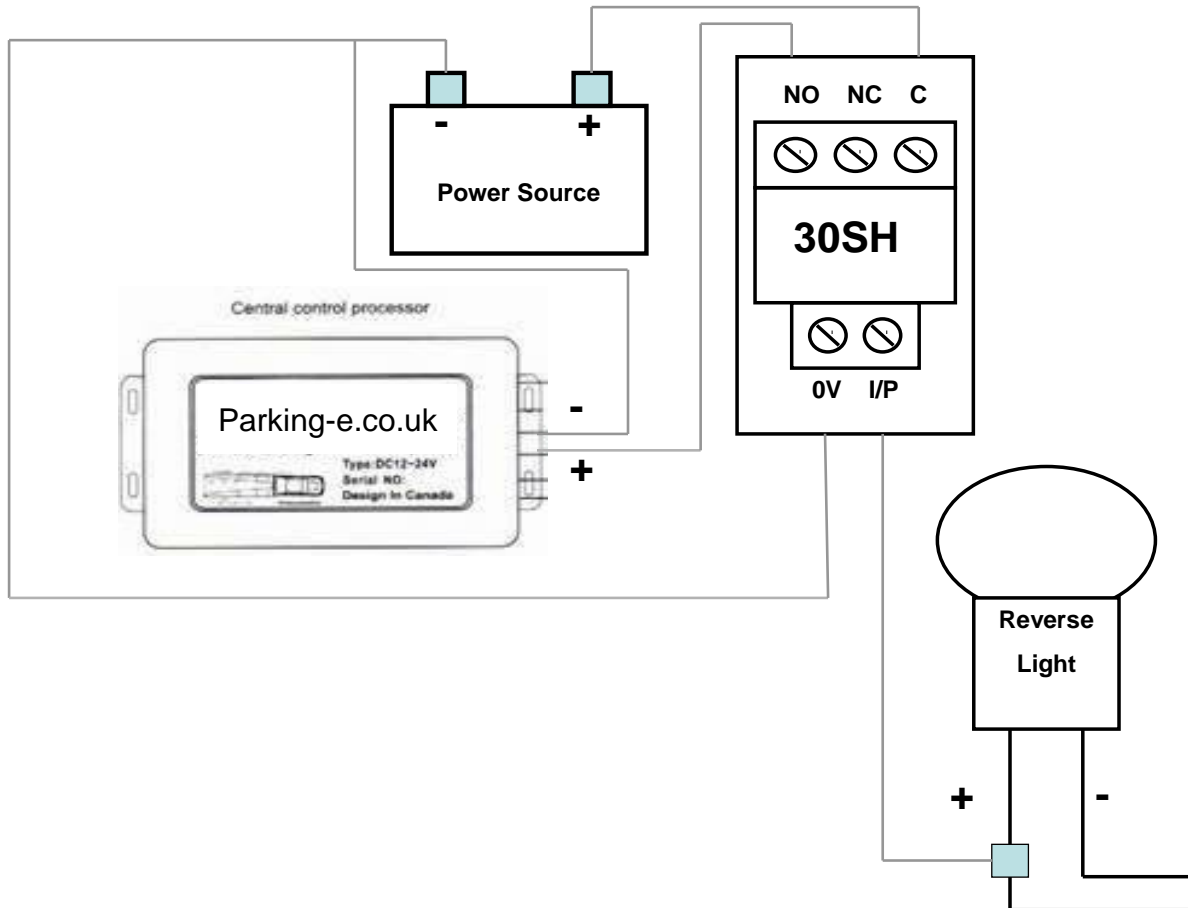

Installation Instructions

1. Connect the terminal marked **I/P** to the vehicle reversing light positive power supply.
2. Connect the terminal marked **C** to an ignition switched fused live (+).
3. Connect the terminal marked **0V** to a good chassis earth. (-)
4. Connect the terminal marked **NO** to the parking sensor positive power lead. (+)
5. Connect the parking sensor negative power lead to a good chassis earth. (-)
6. Check that all connections are secure and well insulated.

Note: This smart switch can only be used on vehicles where the reverse light is switched by a positive power supply. This unit is not compatible with the "S" Type Jaguar.

Supplied by :

ECS Ltd,
www.ecs2.co.uk

Please Note that this system is designed to be a driver's aid and should not replace the need to drive carefully, we accept no liability for damage or loss resulting from improper installation or use of this product, infringement of the vehicle manufacturer's warranty or injury or loss resulting from any accidents however caused. If in doubt please consult a qualified auto electrician.